

NOTES

1. All fins, centering rings, body tubing, and coupler tubing are as supplied in an Air-X "Black Rock" kit.
2. Body tube G12 fiberglass, 5.150" OD, 0.075" wall thickness, cut to 36.750" length. Slotted for three fins.
3. Coupler tube: G12 fiberglass w/ 0.090" wall thickness, 14.000" length.
4. All centering rings are G10 fiberglass.
5. Three fins G10 fiberglass 0.130" thick.

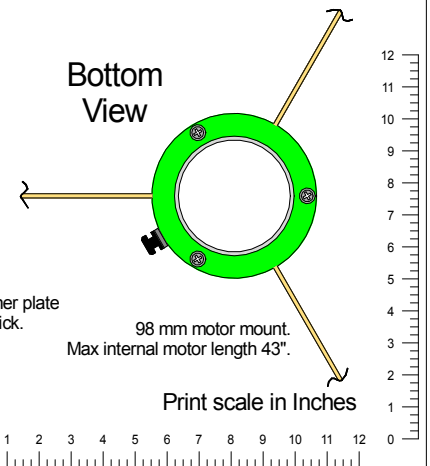

Project: **Angelfire**

All dimensions are in inches
CAD scale: 1" = 6"

Drawing: BOOSTER SECTION

Rev: A

Date: Jan. 29, 2005

By: Vern Knowles

